

---

# INTRODUCTION

	Page
HOW TO USE THIS MANUAL .....	IN-2
IDENTIFICATION INFORMATION .....	IN-4
GENERAL REPAIR INSTRUCTIONS .....	IN-4
PRECAUTIONS FOR VEHICLES EQUIPPED WITH A CATALYTIC CONVERTER .....	IN-7
VEHICLE LIFT AND SUPPORT LOCATIONS .....	IN-8
ABBREVIATIONS USED IN THIS MANUAL .....	IN-10

**IN**

## HOW TO USE THIS MANUAL

To assist you in finding your way through the manual, the Section Title and major heading are given at the top of every page.

An **INDEX** is provided on the first page of each section to guide you to the item to be repaired.

At the beginning of each section, **PRECAUTIONS** are given that pertain to *all* repair operations contained in that section. *Read these precautions before starting any repair task.*

**TROUBLESHOOTING** tables are included for each system to help you diagnose the system problem and find the cause. The repair for each possible cause is referenced in the remedy column to quickly lead you to the solution.

## REPAIR PROCEDURES

Most repair operations begin with an overview illustration. It identifies the components and shows how the parts fit together.

Example:

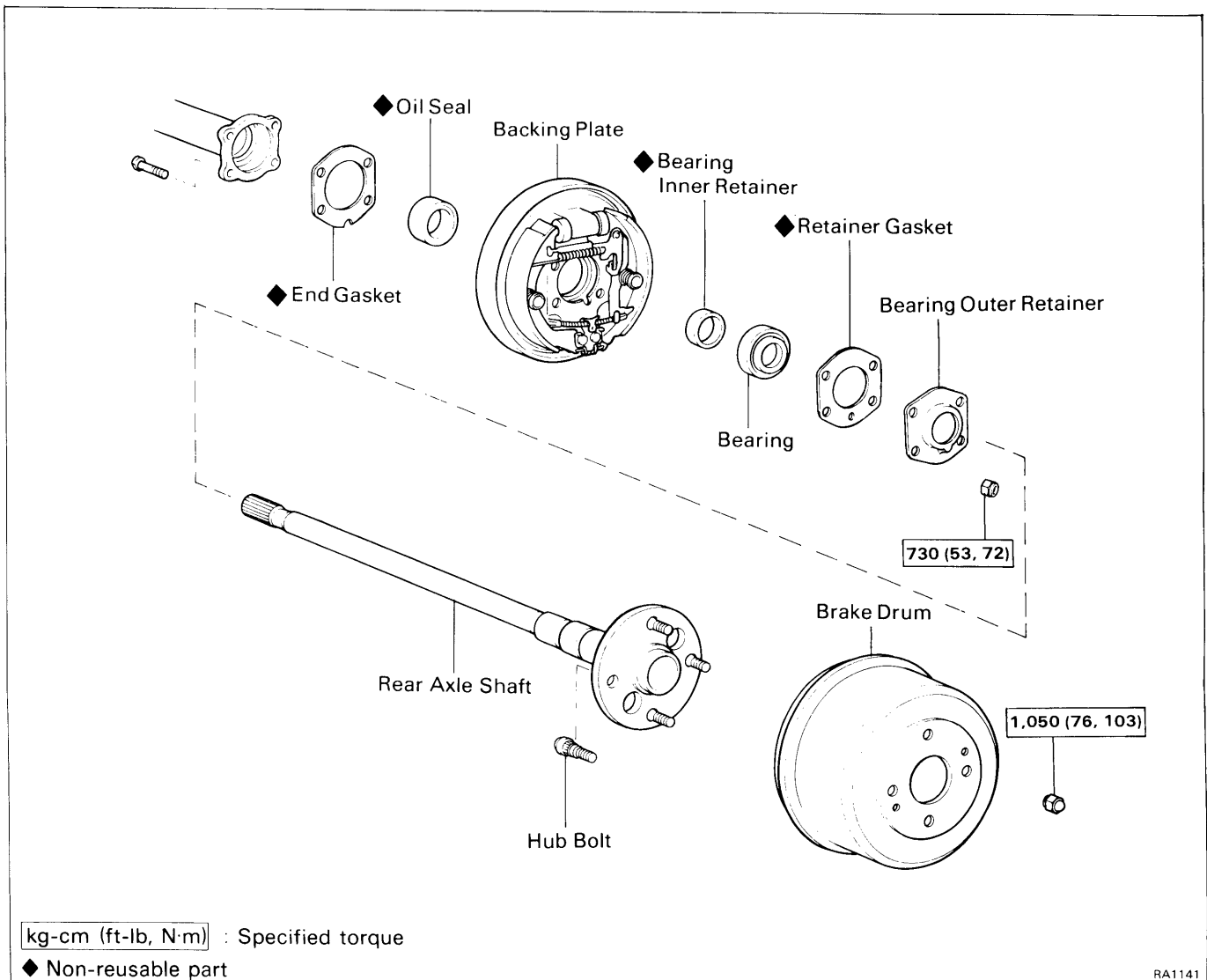

The procedures are presented in a step-by-step format:

- The illustration shows *what* to do and *where* to do it.
- The task heading tells *what* to do.
- The detailed text tells *how* to perform the task and gives other information such as specifications and warnings.

Example:

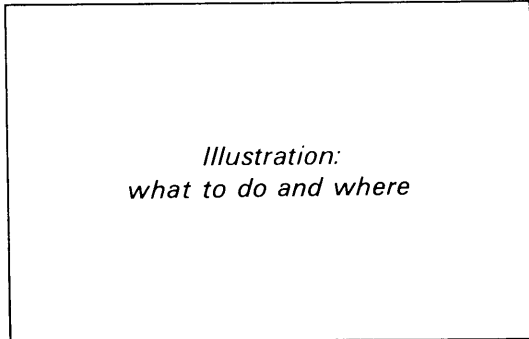

- Task heading: what to do*
- 21. CHECK PISTON STROKE OF OVERDRIVE BRAKE**
- (a) Place SST and a dial indicator onto the overdrive brake piston as shown in the figure.
- SST 09350-30020 (09350-06120)
- Set part No.*                      *Component part No.*
- Detail text: how to do it*
- (b) Measure the stroke applying and releasing the compressed air (4 – 8 kg/cm<sup>2</sup>, 57 – 114 psi or 392 – 785 kPa) as shown in the figure.
- Piston stroke: 1.40 – 1.70 mm (0.0551 – 0.0669 in.)**
- Specification*

This format provides the experienced technician with a FAST TRACK to the information needed. The upper case task heading can be read at a glance and only when necessary, the text below it provides detailed information. Important specifications and warnings always stand out in bold type.

## REFERENCES

References have been kept to a minimum. However, when they are required you are given the *page* to go to.

## SPECIFICATIONS

Specifications are presented in bold type throughout the text in the applicable step. You never have to leave the procedure to look up your specs. All specifications are also found in Appendix A, specifications, for quick reference.

## WARNINGS, CAUTIONS, NOTES:

- **WARNINGS** are presented in bold type, and indicate there is a possibility of injury to you or other people.
- **CAUTIONS** are also presented in bold type, and indicate the possibility of damage to the components being repaired.
- **NOTES** are separated from the text but do not appear in bold. They provide additional information to help you efficiently perform the repair.

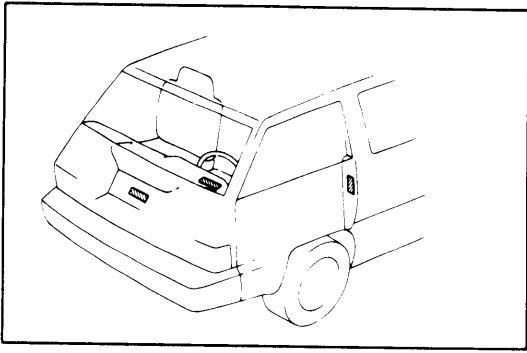

## IDENTIFICATION INFORMATION

### VEHICLE IDENTIFICATION NUMBER

The vehicle identification number is on the left top of the instrument panel.

It is also on the floor pan slope under the front passenger seat and on the driver's door post.

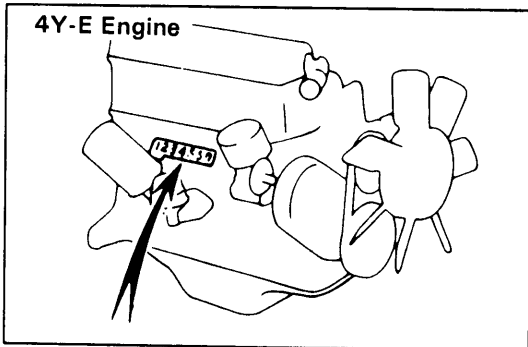

### ENGINE SERIAL NUMBER

The engine serial number is stamped on the right side of the cylinder block.

## GENERAL REPAIR INSTRUCTIONS

1. Use, seat and floor covers to keep the vehicle clean and prevent damage.
2. During disassembly, keep parts in order to facilitate reassembly.
3. Observe the following:
  - (a) Before performing electrical work, disconnect the negative cable from the battery terminal.
  - (b) If it is necessary to disconnect the battery for inspection or repair, always disconnect the cable from the negative (-) terminal which is grounded to the vehicle body.
  - (c) To prevent damage to the battery terminal post, loosen the terminal nut and raise the cable straight up without twisting it or prying it.
  - (d) Clean the battery terminal posts and cable terminals with a shop rag. Do not scrape them with a file or other abrasive object.
  - (e) Install the cable terminal to the battery post with the nut loose, and tighten the nut after installation. Do not use a hammer to tap the terminal onto the post.
  - (f) Be sure the cover for the positive (+) terminal is properly in place.
4. Check hose and wiring connectors to make sure that they are secure and correct.

5. Non-reusable parts
  - (a) Always replace cotter pins, gaskets, O-rings and oil seals etc. with new ones.
  - (b) Non-reusable parts are indicated in the component illustrations by the "◆" symbol.

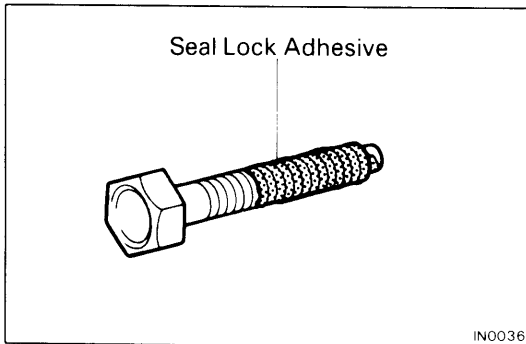

6. Precoated parts

Precoated parts are the bolts and nuts, which have been coated with a seal lock adhesive at the factory.

  - (a) If a precoated part is tightened, loosened or caused to move in any way, it must be recoated with the specified adhesive.
  - (b) Recoating of precoated parts
    - (1) Clean off the old adhesive from the bolt, nut or installation part threads.
    - (2) Dry with compressed air.
    - (3) Apply the specified seal lock adhesive to the bolt or nut threads.
  - (c) Precoated parts are indicated in the component illustrations by the "★" symbol.
7. When necessary, use a sealer on gaskets to prevent leaks.
8. Carefully observe all specifications for bolt tightening torques. Always use a torque wrench.
9. Use of special service tools (SST) and special service materials (SSM) may be required, depending on the nature of the repair. Be sure to use SST and SSM where specified and follow the proper work procedure. A list of SST and SSM can be found at the back of this manual.
10. When replacing fuses, be sure the new fuse has the correct amperage rating. DO NOT exceed the fuse amp rating or use one of a lower rating.
11. Care must be taken when jacking up and supporting the vehicle. Be sure to lift and support the vehicle at the proper locations (See pages IN-8, 9).
  - (a) If the vehicle is to be jacked up only at the front or rear end, be sure to block the wheels in order to ensure safety.
  - (b) After the vehicle is jacked up, be sure to support it on stands. It is extremely dangerous to do any work on the vehicle raised on jack alone, even for a small job that can be finished quickly.

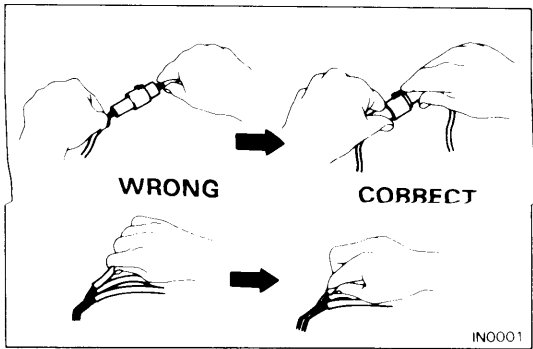

12. Observe the following precautions to avoid damage to the parts:
- To disconnect vacuum hoses, pull on the end, not the middle of the hose.
  - To pull apart electrical connectors, pull on the connector itself, not the wires.
  - Be careful not to drop electrical components, such as sensors or relays. If they are dropped on a hard floor, they should be replaced and not reused.
  - When steam cleaning an engine, protect the IIA, from water.
  - Never use an impact wrench to remove or install thermo switches or thermo sensors.
  - When checking continuity at the wire connector, insert the tester probe carefully to prevent terminals from bending.
  - When using a vacuum gauge, never force the hose onto a connector that is too large. Use a step-down adapter instead. Once the hose has been stretched, it may leak.

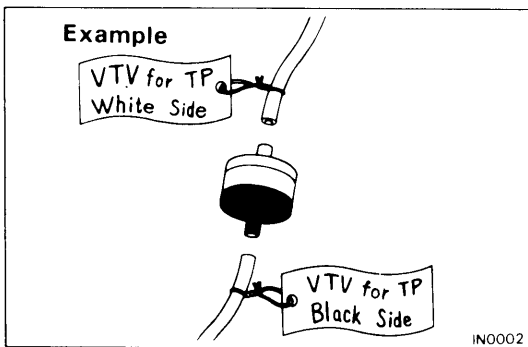

13. Tag hoses before disconnecting them:
- When disconnecting vacuum hoses, use tags to identify how they should be reconnected.
  - After completing a job, double check that the vacuum hoses are properly connected. A label on the floor pan shows the proper layout.

## PRECAUTIONS FOR VEHICLES EQUIPPED WITH A CATALYTIC CONVERTER

**WARNING:** If large amounts of unburned gasoline flow into the converter, it may overheat and create a fire hazard. To prevent this, observe the following precautions and explain them to your customer.

1. **Use only unleaded gasoline.**
2. **Avoid prolonged idling.**  
Avoid running the engine at idle speed for more than 20 minutes.
3. **Avoid spark jump test.**
  - (a) Spark jump test only when absolutely necessary. Perform this test as rapidly as possible.
  - (b) While testing, never race the engine.
4. **Avoid prolonged engine compression measurement.**  
Engine compression tests must be made as rapidly as possible.
5. **Do not run engine when fuel tank is nearly empty.**  
This may cause the engine to misfire and create an extra load on the converter.
6. **Avoid coasting with ignition turned off and prolonged braking.**
7. **Do not dispose of a used catalyst along with parts contaminated with gasoline or oil.**

# VEHICLE LIFT AND SUPPORT LOCATIONS

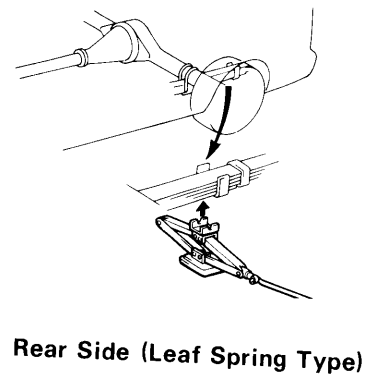
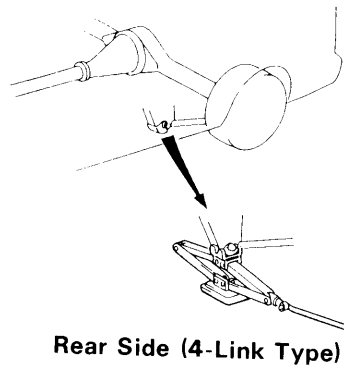
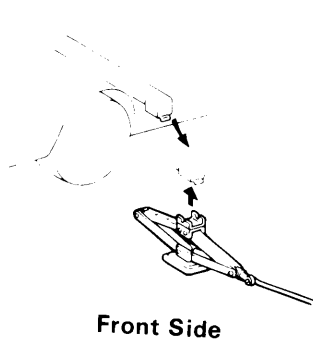
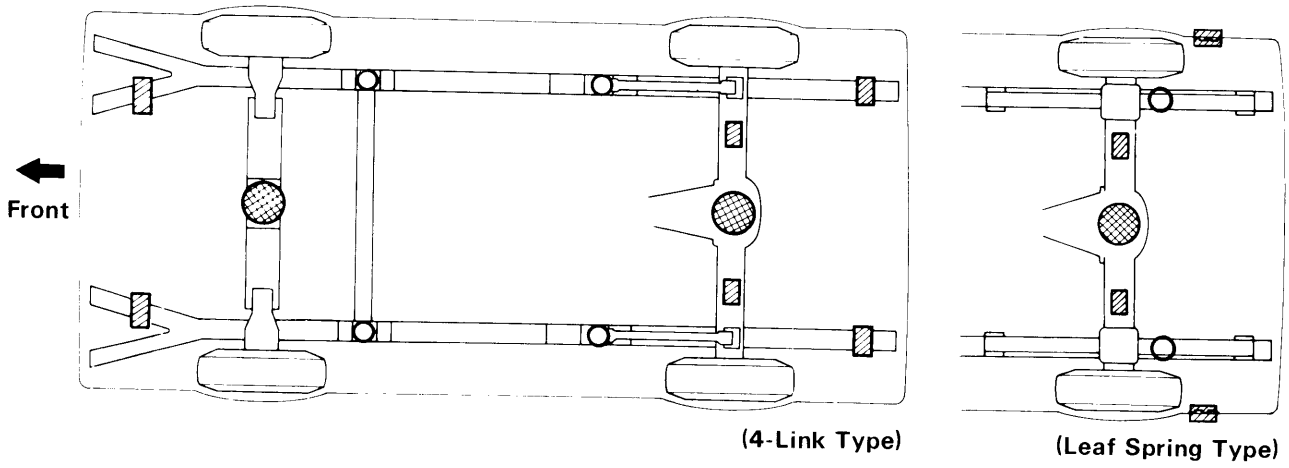

**JACK POSITION** ————— ●

Front ..... Center of front suspension crossmember

Rear ..... Center of rear axle housing

**PANTOGRAPH JACK POSITION** ————— ○

**SUPPORT POSITION**

Safety stand ..... ▨

## VEHICLE LIFT AND SUPPORT LOCATIONS (Cont'd)

**SWING ARM TYPE LIFT**

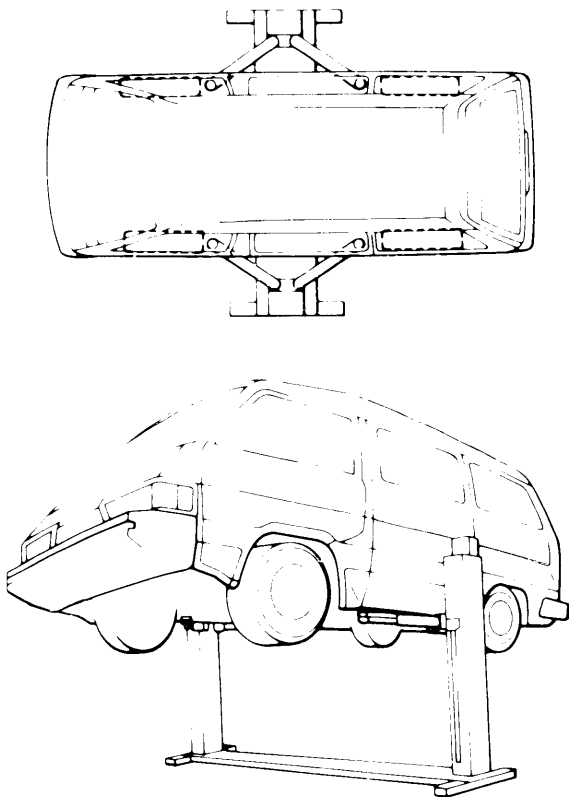

**PLATE TYPE LIFT**

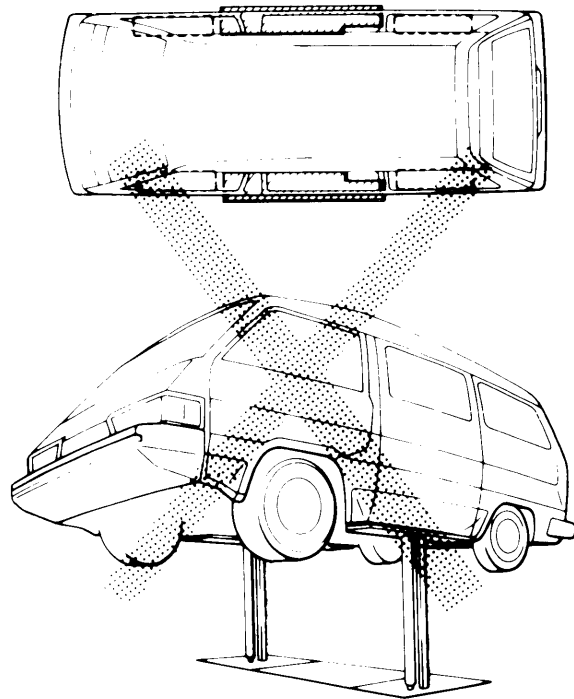

**SWING ARM TYPE LIFT**

Support position:

Front ... Engine front mounting member

Rear ... Lower control arm installation bracket (4-Link Type)

Leaf spring front hanger (Leaf Spring Type)

**PLATE TYPE LIFT**

**Do not use a plate type lift as illustrated above right as it would damage the battery case and rear heater unit.**

## ABBREVIATIONS USED IN THIS MANUAL

A/C	Air Conditioner
ALH	Automatic Locking Hub
A/T, ATM	Automatic Transmission
ATDC	After Top Dead Center
ATF	Automatic Transmission Fluid
B <sub>0</sub>	Overdrive Brake
B <sub>1</sub>	No. 1 Brake
B <sub>2</sub>	No. 2 Brake
B <sub>3</sub>	No. 3 Brake
BDC	Bottom Dead Center
BTDC	Before Top Dead Center
BVSV	Bimetal Vacuum Switching Valve
C <sub>0</sub>	Overdrive Clutch
C <sub>1</sub>	Front Clutch
C <sub>2</sub>	Rear Clutch
DP	Dash Pot
ECU	Electronic Controlled Unit
EFI	Electronic Fuel Injection
EGR	Exhaust Gas Recirculation
ESA	Electronic Spark Advance
EVAP	Evaporative (Emission Control)
EX	Exhaust (manifold, valve)
Ex.	Except
F <sub>0</sub>	Overdrive One-way Clutch
F <sub>1</sub>	No. 1 One-way Clutch
F <sub>2</sub>	No. 2 One-way Clutch
FIPG	Formed in Place Gasket
FR, Fr	Front
IG	Ignition
IN	Intake (manifold, valve)
in.	Inch
ISC	Idle Speed Control
LH	Left-hand
LHD	Left-hand Drive
Max.	Maximum
MP	Multipurpose
M/T, MTM	Manual Transmission
OD	Overdrive
OPT	Option
O/S	Oversize
PCV	Positive Crankcase Ventilation
OWC	One-way Clutch
PS	Power Steering
RH	Right-hand
RHD	Right-hand Drive
SSM	Special Service Materials
SST	Special Service Tools
STD	Standard
S/W	Switch
TDC	Top Dead Center
TWC	Three-way Catalyst
U/S	Undersize
VSV	Vacuum Switching Valve
VTV	Vacuum Transmitting Valve
w/	With
w/o	Without
2WD	Two Wheel Drive Vehicles (4 × 2)
4WD	Four Wheel Drive Vehicles (4 × 4)