STARTING SYSTEM

	Page
TROUBLESHOOTING	ST-2
STARTER	ST-3
STARTER RELAY (M/T ONLY).....	ST-12
CLUTCH START SWITCH (M/T ONLY)	ST-12

ST

TROUBLESHOOTING

Problem	Possible cause	Remedy	Page
Engine will not crank	Battery charge low	Check battery specific gravity Charge or replace battery	CH-3
	Battery cables loose, corroded or worn Neutral start switch faulty (A/T) Fusible link blown Starter faulty Ignition switch faulty	Repair or replace cables Adjust or repair switch Replace fusible link Repair starter Replace ignition switch	ST-3
Engine cranks slowly	Battery charge low	Check battery specific gravity Charge or replace battery	CH-3
	Battery cables loose, corroded or worn Starter faulty	Repair or replace cables Repair starter	ST-3
Starter keeps running	Starter faulty Ignition switch faulty Short in wiring	Repair starter Replace ignition switch Repair wiring	ST-3
Starter spins – engine will not crank	Pinion gear teeth broken or starter faulty Flywheel teeth broken	Repair starter Replace flywheel	ST-3

STARTER COMPONENTS

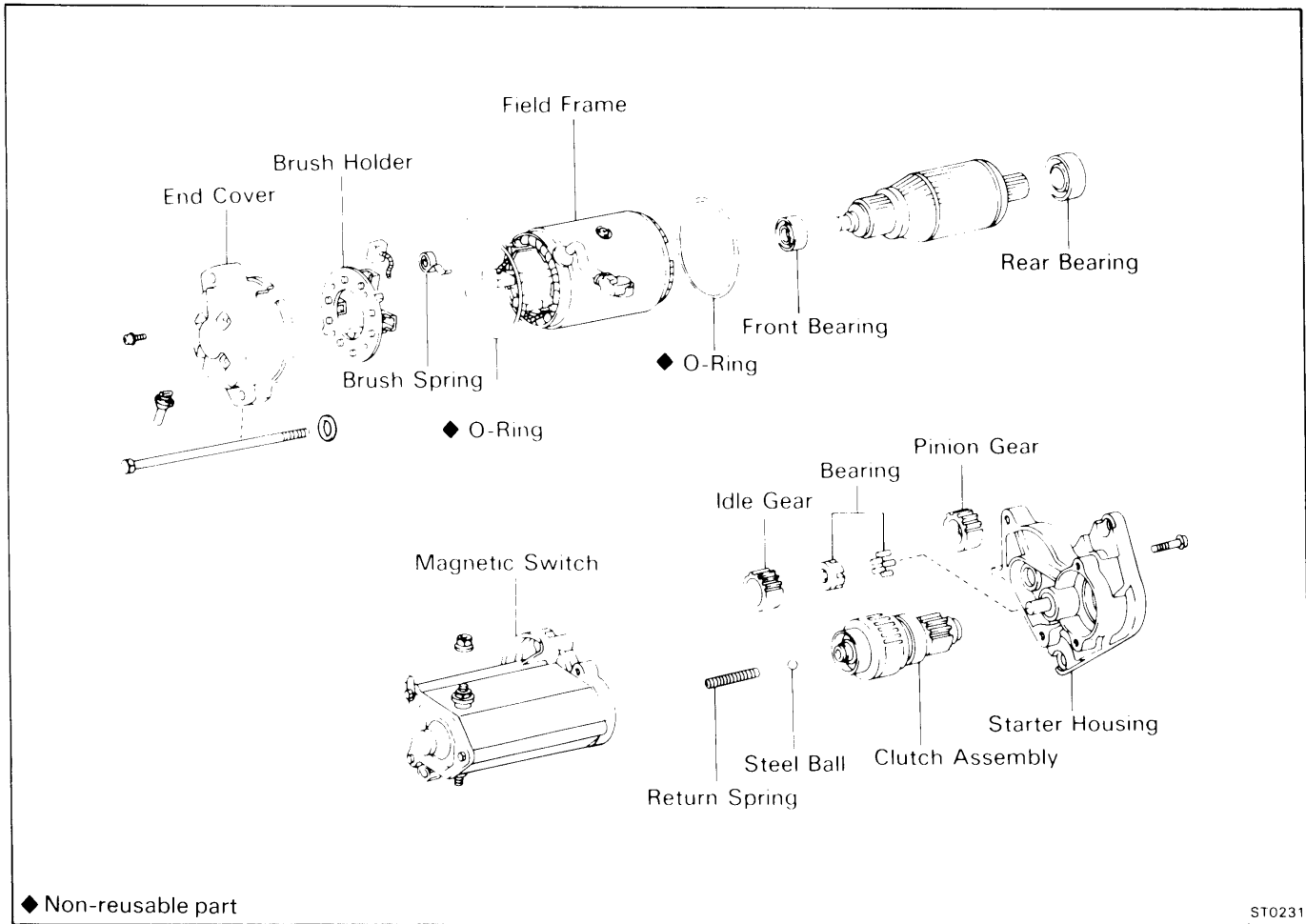

REMOVAL OF STARTER

1. DISCONNECT CABLE FROM NEGATIVE TERMINAL OF BATTERY
2. DISCONNECT CONNECTOR AND WIRE FROM STARTOR

3. REMOVE STARTER

Remove the two bolts, and then remove the starter from the flywheel bell-housing.

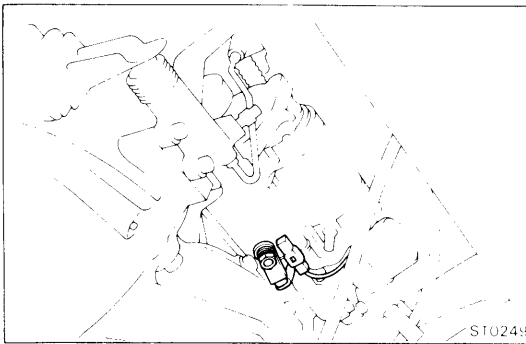

DISASSEMBLY OF STARTER

(See page ST-3)

1. REMOVE FIELD FRAME AND ARMATURE ASSEMBLY

- (a) Disconnect the lead wire from the magnetic switch terminal.
- (b) Remove the two through bolts. Pull out the field frame together with the armature from the magnetic switch.
- (c) Remove the O-ring.

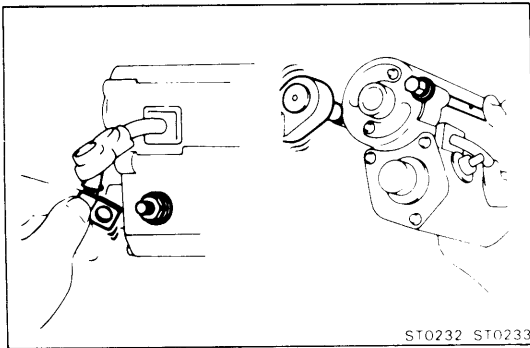

2. REMOVE STARTER HOUSING, CLUTCH ASSEMBLY AND GEARS

- (a) Remove the two screws.

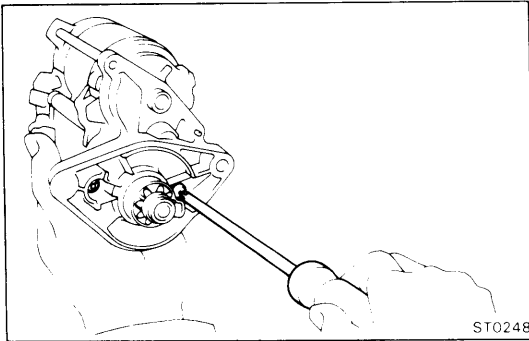

- (b) Remove the following parts from the magnetic switch:

- (1) Starter housing
- (2) Pinion gear
- (3) Bearing
- (4) Idler gear
- (5) Clutch assembly
- (6) Return spring

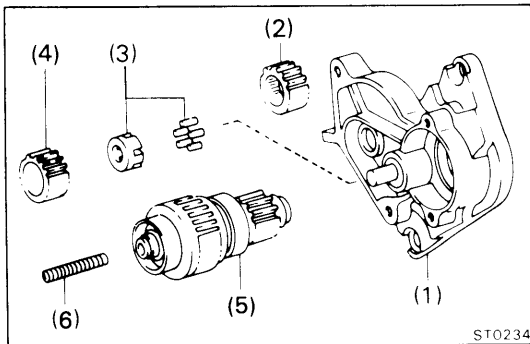

3. REMOVE STEEL BALL

Using a magnetic finger, remove the steel ball from the clutch shaft hole.

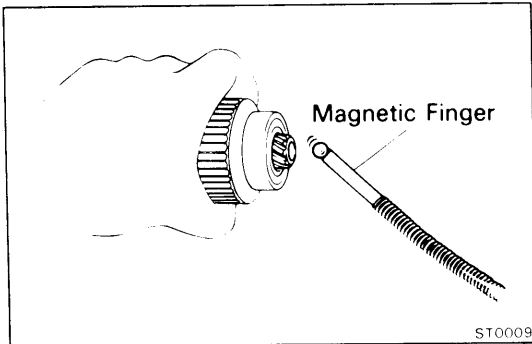

4. REMOVE BRUSH HOLDER

- (a) Remove the two screws and end cover from the field frame.
- (b) Remove the O-ring.

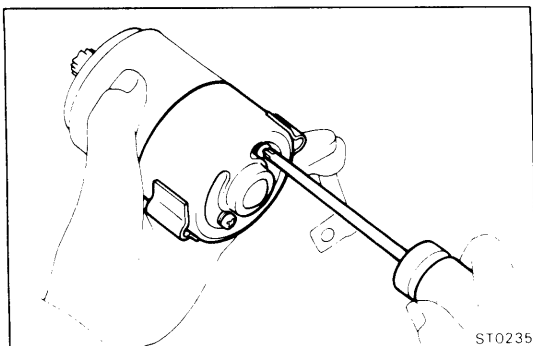

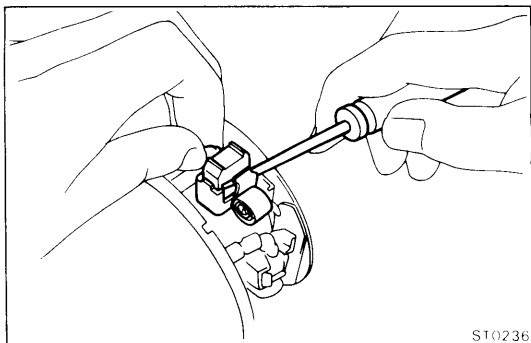

- (c) Using a screwdriver, hold the spring back and disconnect the brush from the brush holder. Disconnect the four brushes and remove the brush holder.

5. REMOVE ARMATURE FROM FIELD FRAME

INSPECTION OF STARTER

Armature Coil

1. INSPECT COMMUTATOR FOR OPEN CIRCUIT

Using an ohmmeter, check that there is continuity between the segments of the commutator.

If there is no continuity, replace the armature.

2. INSPECT COMMUTATOR FOR GROUND

Using an ohmmeter, check that there is no continuity between the commutator and armature coil core.

If there is continuity, replace the armature.

Commutator

1. INSPECT COMMUTATOR FOR DIRTY AND BURNT SURFACES

If the surface is dirty or burnt, correct with sandpaper (No. 400) or on a lathe.

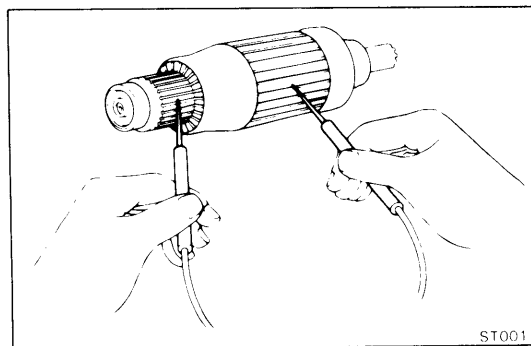
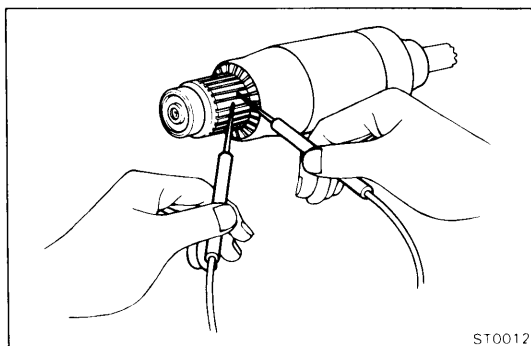

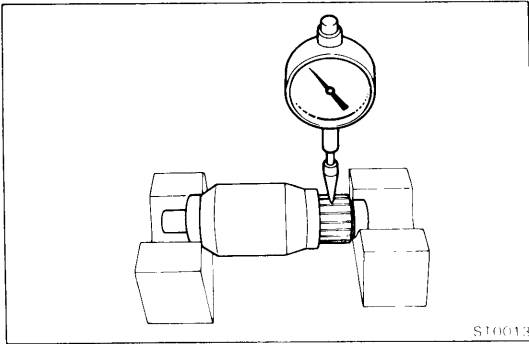

2. INSPECT COMMUTATOR CIRCLE RUNOUT

Maximum circle runout: 0.05 mm (0.0020 in.)

If the circle runout is greater than maximum, correct it on a lathe.

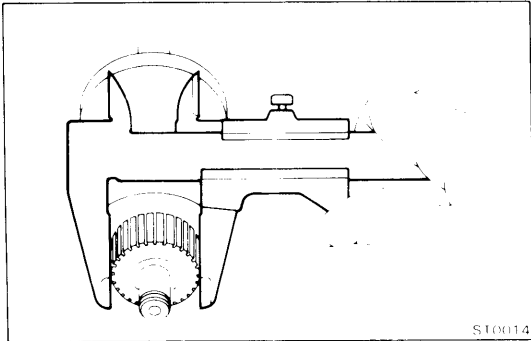

3. INSPECT DIAMETER OF COMMUTATOR

Standard diameter: 30 mm (1.18 in.)

Minimum diameter: 29 mm (1.14 in.)

If the diameter of the commutator is less than minimum, replace the armature.

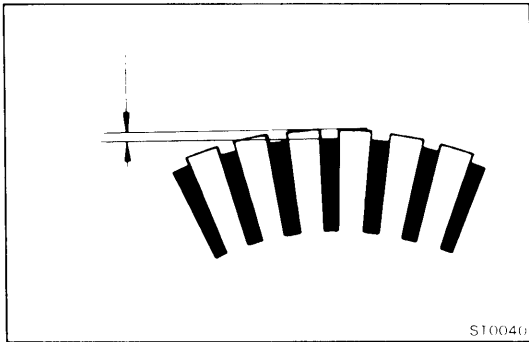

4. INSPECT UNDERCUT DEPTH

Check that the undercut depth is clean and free of foreign material. Smooth out the edge.

Standard undercut depth: 0.6 mm (0.024 in.)

Minimum undercut depth: 0.2 mm (0.008 in.)

If the undercut depth is less than minimum, correct it with a hacksaw blade.

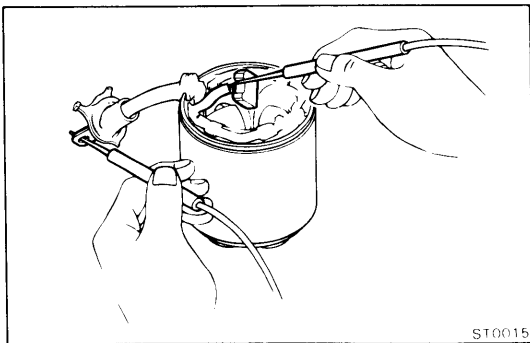

Field Coil (Field Frame)

1. INSPECT FIELD COIL FOR OPEN CIRCUIT

Using an ohmmeter, check that there is continuity between the lead wire and field coil brush lead.

If there is no continuity, replace the field frame.

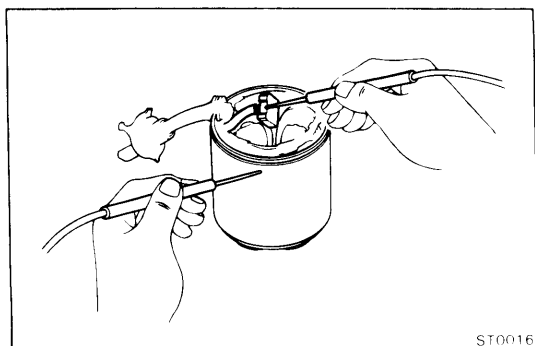

2. INSPECT FIELD COIL FOR GROUND

Using an ohmmeter, check that there is no continuity between the field coil end and field frame.

If there is continuity, repair or replace the field frame.

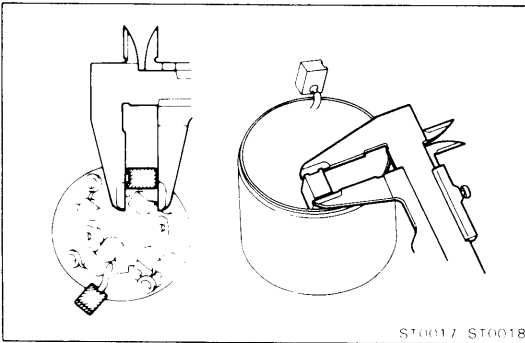

Brushes

INSPECT BRUSH LENGTH

Standard length: 15.5 mm (0.610 in.)

Minimum length: 10.0 mm (0.394 in.)

If the length is less than minimum, replace the brush holder and field frame.

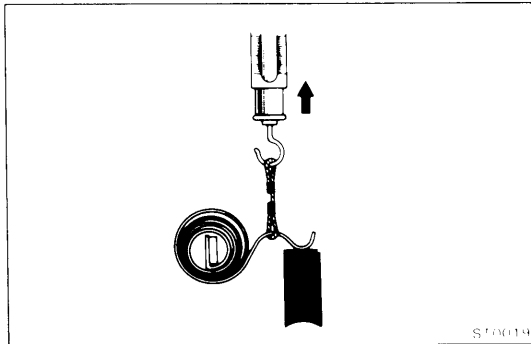

Brush Springs

INSPECT BRUSH SPRING LOAD WITH PULL SCALE

Spring installed load:

1.79 – 2.41 kg (3.9 – 5.3 lb, 18 – 24 N)

NOTE: Take the pull scale reading the instant the brush spring separates from the brush.

If the reading is not within specification, replace the brush springs.

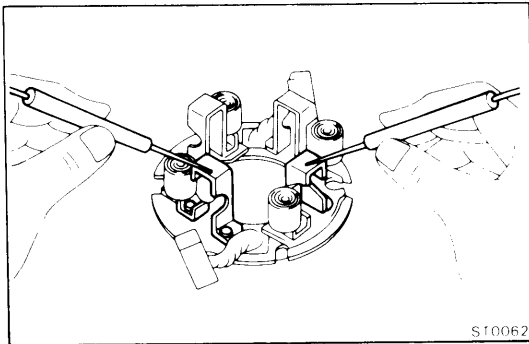

Brush Holder

INSPECT INSULATION OF BRUSH HOLDER

Using an ohmmeter, check that there is no continuity between the positive (+) and negative (-) brush holders.

If there is continuity, repair or replace the brush holder.

Clutch and Gears

1. INSPECT GEAR TEETH

Check the gear teeth on the pinion gear, idler gear and clutch assembly for wear or damage. Replace if damaged.

If damaged, also check the flywheel ring gear for wear or damage.

2. INSPECT CLUTCH PINION GEAR

Rotate the pinion gear clockwise and check that it turns freely. Try to rotate the pinion gear counterclockwise and check that it locks.

If necessary, replace the clutch assembly.

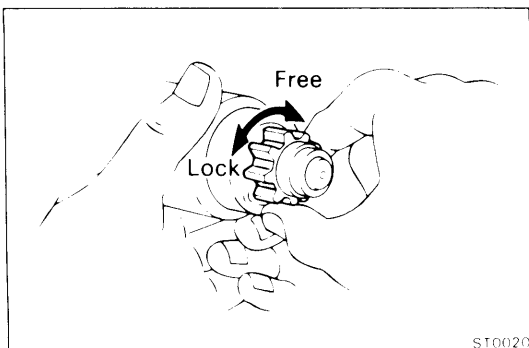

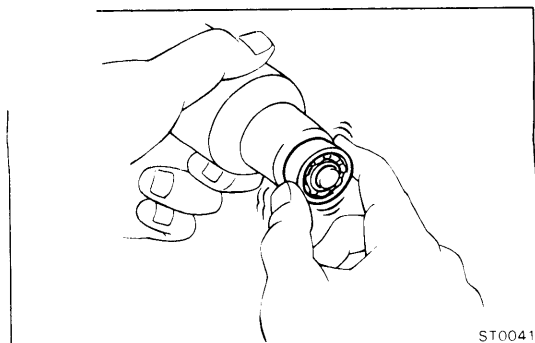

Bearings

1. INSPECT BEARINGS

Turn each bearing by hand while applying inward force. If resistance is felt or if either bearing sticks, replace the bearing.

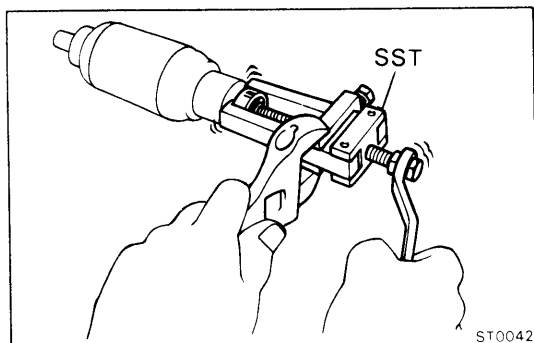

2. IF NECESSARY, REPLACE BEARINGS

- (a) Using SST, remove the bearing from the armature shaft.
- (b) Using SST, remove the other bearing on the opposite side.

SST 09286-46011

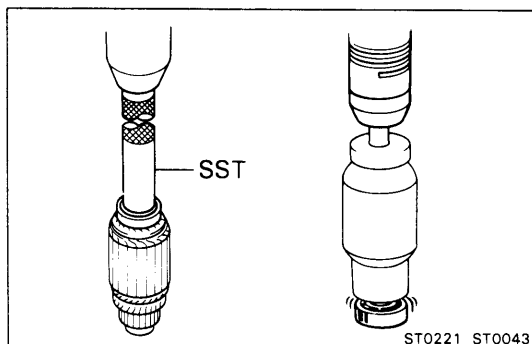

- (c) Using SST and a press, press in a new front bearing.
SST 09201-41020

- (d) Using a press, press in a new rear bearing.

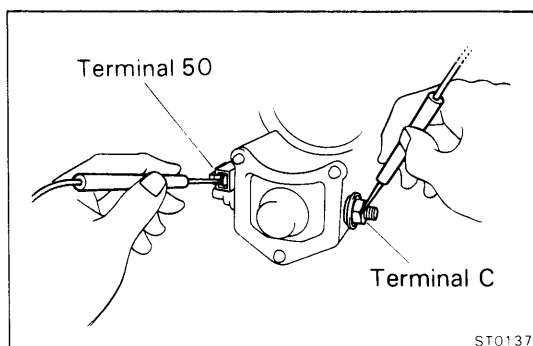

Magnetic Switch

1. PERFORM PULL-IN COIL OPEN CIRCUIT TEST

Using an ohmmeter, check that there is continuity between terminals 50 and C.

If there is no continuity, replace the magnetic switch.

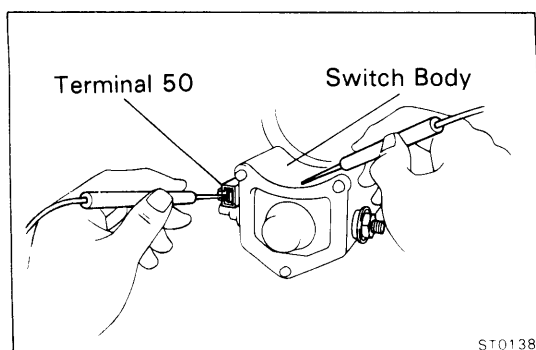

2. PERFORM HOLD-IN COIL OPEN CIRCUIT TEST

Using an ohmmeter, check that there is continuity between terminal 50 and the switch body.

If there is no continuity, replace the magnetic switch.

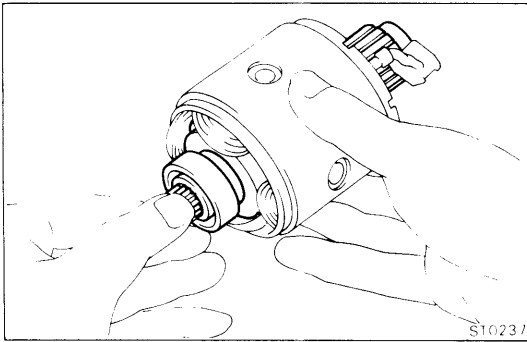

ST0237

ASSEMBLY OF STARTER

(See page ST-3)

NOTE: Use high-temperature grease to lubricate the bearings and gears when assembling the starter.

1. PLACE ARMATURE INTO FIELD FRAME

Apply grease to the armature bearings and insert the armature into the field frame.

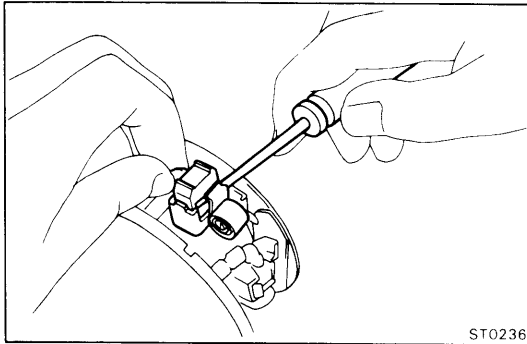

ST0236

2. INSTALL BRUSH HOLDER

- (a) Using a screwdriver, hold the brush spring back, and connect the brush into the brush holder. Connect the four brushes.

NOTE: Check that the positive (+) lead wires are not grounded.

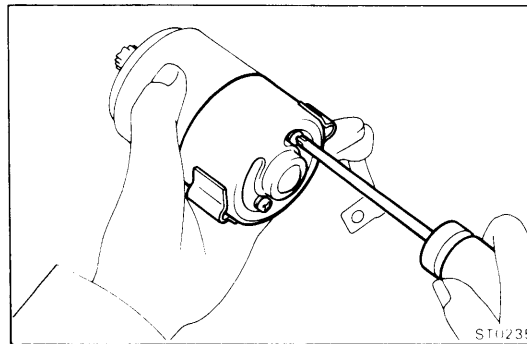

ST0235

- (b) Place a new O-ring in position on the field frame.

- (c) Install the end cover with the two screws.

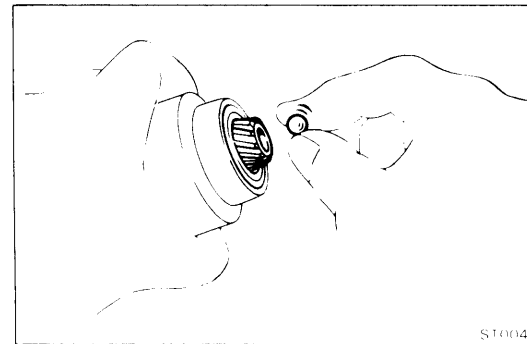

ST0044

3. INSERT STEEL BALL INTO CLUTCH SHAFT HOLE

Apply grease to the ball, and insert it into the clutch shaft hole.

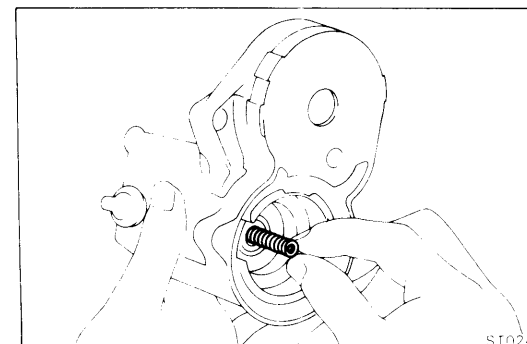

ST0244

4. INSTALL CLUTCH ASSEMBLY AND GEAR

- (a) Apply grease to the clutch assembly, gears, bearing and return spring.

- (b) Insert the return spring into the magnetic switch.

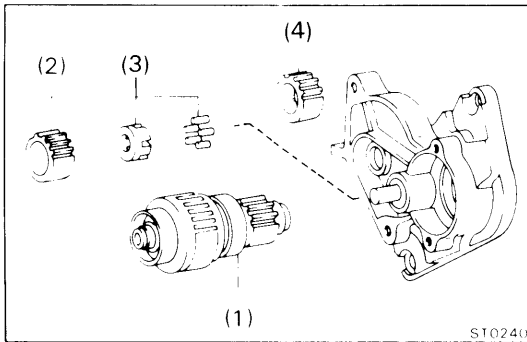

- (c) Place the following parts in position on the starter housing.
- (1) Clutch assembly
 - (2) Idler gear
 - (3) Bearing
 - (4) Pinion gear

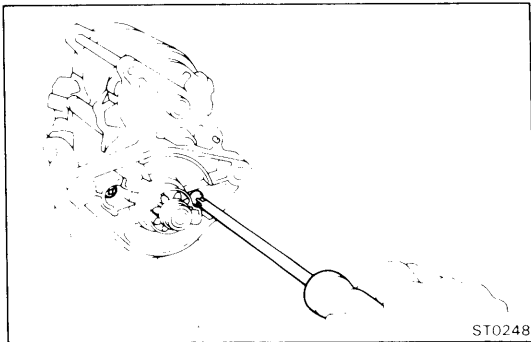

- (d) Assemble the starter housing and magnetic switch with the two screws.

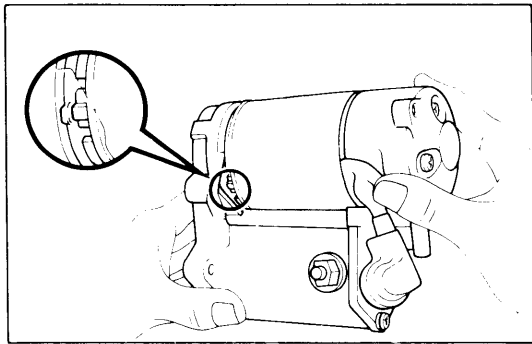

5. INSTALL FIELD FRAME AND ARMATURE ASSEMBLY

- (a) Place a new O-ring in position on the field frame.
- (b) Align the protrusion of the field frame with the cutout of the magnetic switch.

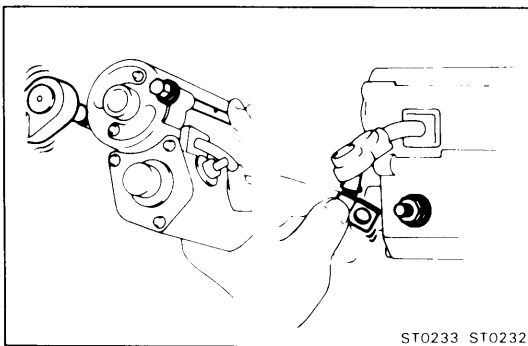

- (c) Install the two through bolts.
- (d) Connect the lead wire to the magnetic switch terminal, and install the nut.

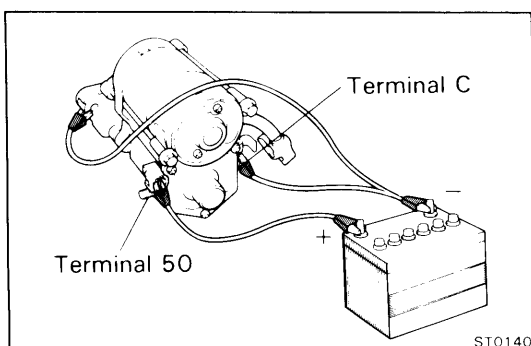

PERFORMANCE TEST OF STARTER

CAUTION: These tests must be performed within 3 to 5 seconds to avoid burning out the coil.

1. PERFORM PULL-IN TEST

- (a) Disconnect the field coil lead from terminal C.
- (b) Connect the battery to the magnetic switch as shown. Check that the pinion gear moves outward.

If the pinion gear does not move, replace the magnetic switch assembly.

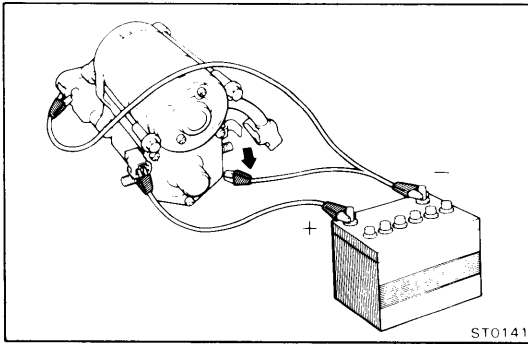

2. PERFORM HOLD-IN TEST

While connected as above with the pinion gear out, disconnect the negative (-) lead from terminal C. Check that the pinion gear remains out.

If the pinion gear returns inward, replace the magnetic switch assembly.

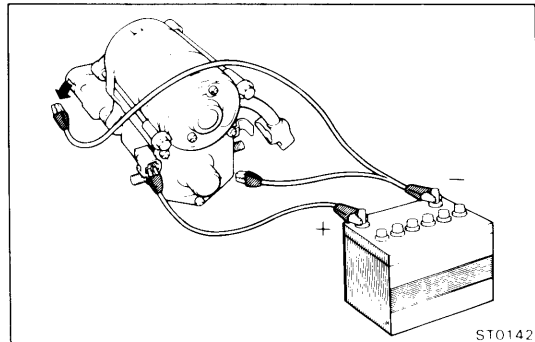

3. INSPECT PLUNGER RETURN

Disconnect the negative (-) lead from the switch body. Check that the pinion gear returns inward.

If the pinion gear does not return, replace the magnetic switch assembly.

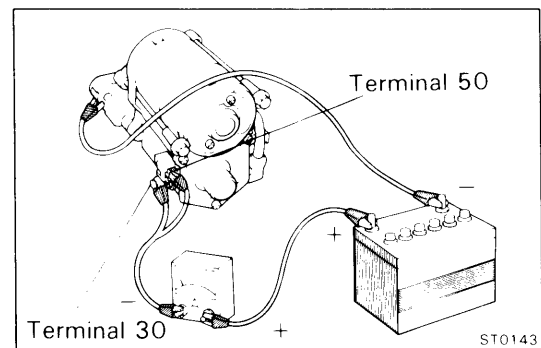

4. PERFORM NO-LOAD PERFORMANCE TEST

- (a) Connect the battery and ammeter to the starter as shown.
- (b) Check that the starter rotates smoothly and steadily with the pinion gear moving out. Check that the ammeter reads the specified current.

Specified current: 90A or less at 11.5V

INSTALLATION OF STARTER

1. INSTALL STARTER

- (a) Place the starter in position in the flywheel bell housing.
- (b) Install and torque the two bolts.

Torque: 380 kg-cm (27 ft-lb, 37 N·m)

2. CONNECT CONNECTOR AND WIRE TO STARTER

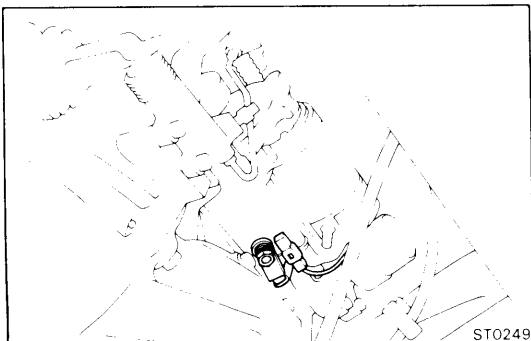

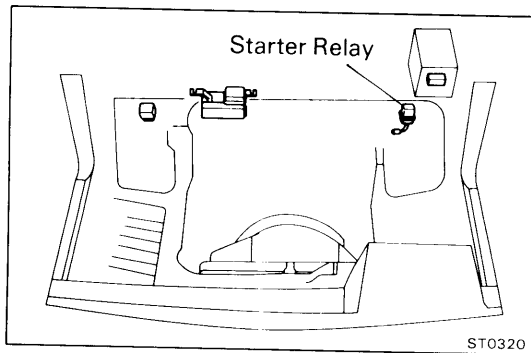

STARTER RELAY (M/T ONLY)

LOCATION: In the engine compartment on the left side.

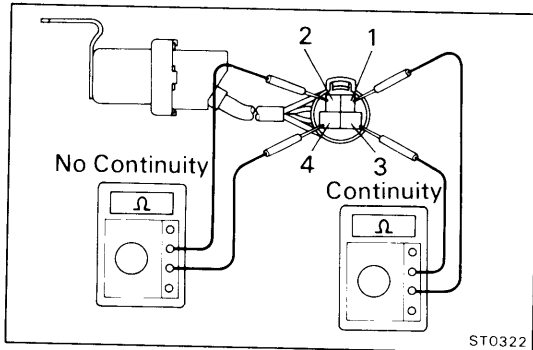

INSPECTION OF STARTER RELAY

1. INSPECT RELAY CONTINUITY

- (a) Using an ohmmeter, check that there is continuity between terminals 1 and 3.
- (b) Check that there is no continuity between terminals 2 and 4.

If continuity is not as specified, replace the relay.

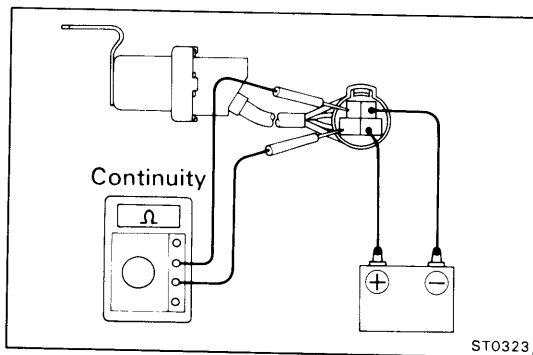

2. INSPECT RELAY OPERATION

- (a) Apply battery voltage across terminals 1 and 3.
- (b) Using an ohmmeter, check that there is continuity between terminals 2 and 4.

If operation is not as specified, replace the relay.

CLUTCH START SWITCH (M/T ONLY)

(See page CL-4)